

Zeppelin NT airships

Peter Lobner, updated 12 February 2022

1. Introduction

The ZLT Zeppelin Luftschifftechnik GmbH, based in Friedrichshafen, Germany, on Lake Constance, was established in September 1993 for the development, manufacture and sale of airships of the Zeppelin NT (New Technology) brand. Through its owners, Luftschiffbau Zeppelin GmbH and ZF Friedrichshafen AG, today's firm, ZLT Zeppelin, has a direct lineage back to companies founded more than a century ago by Ferdinand Graf von Zeppelin (1838–1917), prior to the development and manufacture of dirigibles.

The basic design of the Zeppelin NT is defined in several patents that have been assigned to Luftschiffbau Zeppelin GmbH. An overview of two of these patents is included at the end of this article.

In 1991, the Luftfahrtbundesamt (German CAA) issued the Zeppelin NT Type Certificate and approved ZLT Zeppelin Luftschifftechnik GmbH as an aircraft manufacturer. The first Zeppelin NT made its first flight on 18 September 1997. Through mid-2021, nine Zeppelin NT-class semi-rigid airships have been built.

ZLT Zeppelin Luftschifftechnik GmbH maintains an extensive website on the Zeppelin NT here: <https://zeppelin-nt.de/en/zeppelin-NT.html>

2. The Zeppelin NT airship

Zeppelin NT airships have a rigid internal structure made of composite material and aluminum, an innovative drive concept using vectored thrust propellers, and a "fly-by-wire" flight control system. These features significantly extend the application limits of previous airships. With the Zeppelin NT's low-speed maneuverability during takeoff and landing, the typically labor-intensive ground handling tasks are greatly simplified. The airship requires only a three person ground crew for normal operation.



Installing the flexible fabric envelope over the Zeppelin NT's rigid internal structure. Source: Screenshots from video, ZLT Zeppelin Luftschifftechnik GmbH

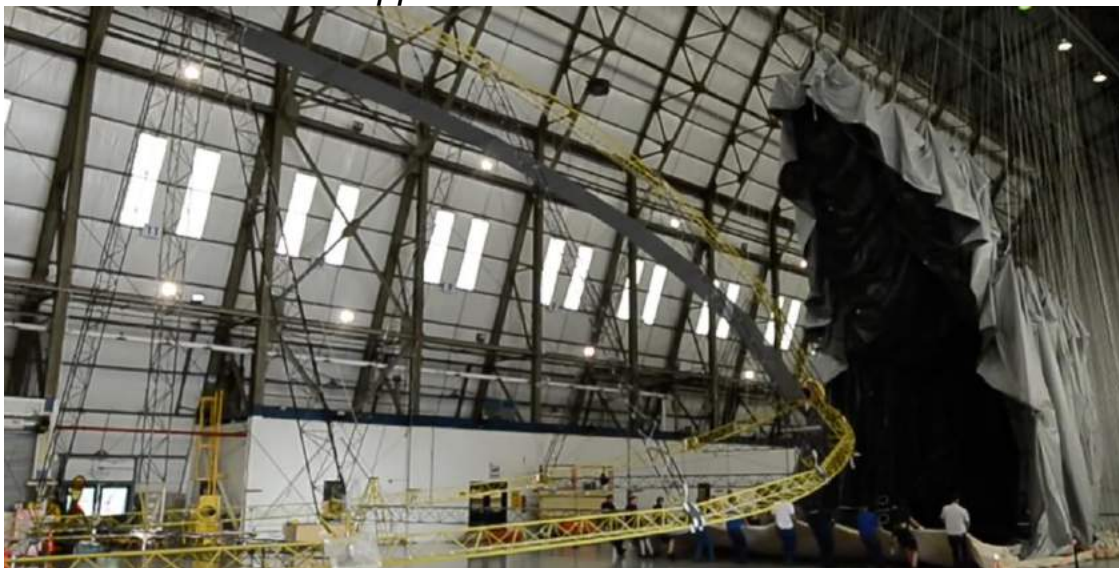

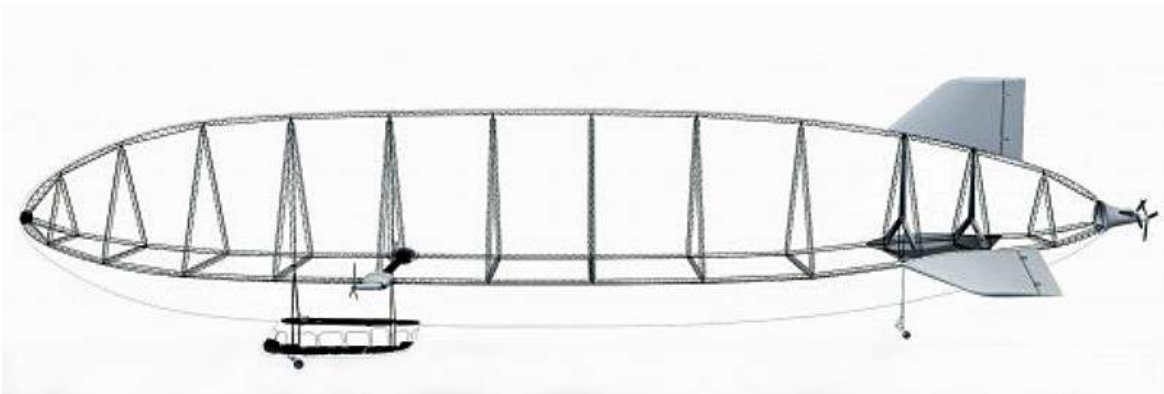

Zeppelin NT's rigid internal framework supports the gondola, engines and tail fins. Source: ZLT Zeppelin Luftschifftechnik GmbH

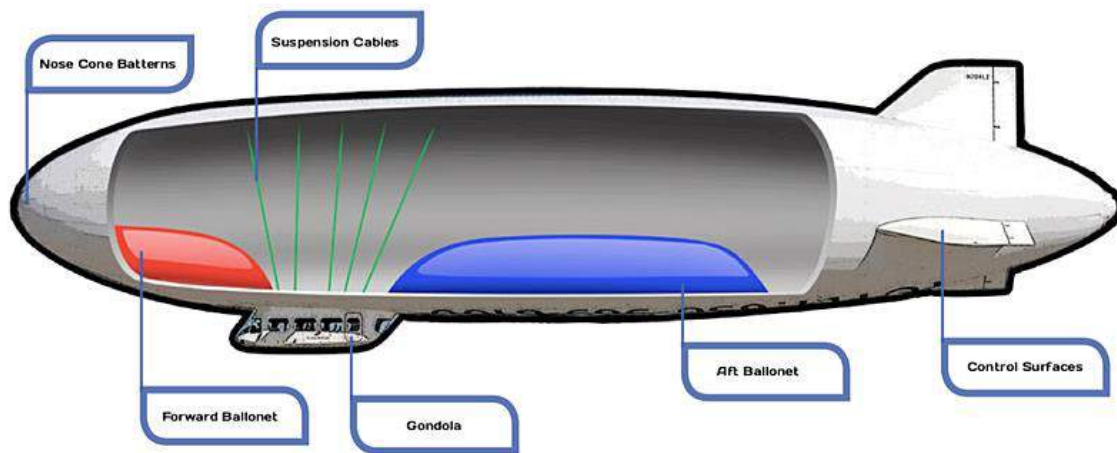

Cross-section of the Zeppelin NT showing the locations of the ballonets and the suspension cables securing the gondola to the rigid internal frame. Source: Anatomy of an airship, <https://static1.squarespace.com>

The Zeppelin NT is longer than a Boeing 747-400 airliner. The airship's rigid primary structure weighs only about 1,000 kg (2,200 lb) and the empty weight of a complete Zeppelin NT with the gas envelope is about 6,622 kg (14,599 lb). In comparison, the empty weight of a Boeing 747-400 is 184,567 kg (406,900 lb).

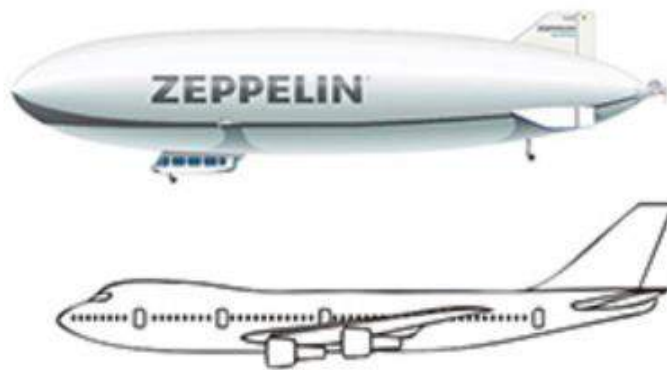

Zeppelin NT
246 ft / 75 m

Boeing 747-400
232 ft / 71 m

*Zeppelin NT & Boeing 747-400 size comparison.
Source: ZLT Zeppelin Luftschifftechnik GmbH*

Basic design parameters of the Zeppelin NT are as follows:

Parameter	Zeppelin NT
Airship type	Semi-rigid
Length	75 m (246 ft)
Diameter	14.2 m (46.4 ft)
Volume	8,425 m ³ (297,526 ft ³)
Ballonet volume	2,000 m ³ (71,000 ft ³)
Gross weight	10,690 kg (23,567 lb)
Payload	1,900 kg (4,180 lb), including passengers
Accommodations	Gondola for 2 flight crew and 12 passengers
Propulsion system	3 x Textron Lycoming IO-360 flat-4 air-cooled gasoline engines @ 149 kW (200 hp) each
Speed	Up to 125 kph (77 mph), 115 kph (71 mph) cruise
Range	900 km (559 miles)
Altitude, service ceiling	2,600 m (8,530 ft)
Altitude, maximum	3,000 m (9,842 ft)
Ballast	Water
Endurance	Up to 24 hours

In normal operation, the Zeppelin NT is trimmed for about 5% (maximum 400 kg, 882 lb) negative buoyancy (i.e., the lift gas cells do not create quite enough buoyant lift to make the Zeppelin NT lighter-than-air). At takeoff and landing, negative buoyancy is overcome with the application of engine power to three vectored-thrust propellers (two flank, one stern) that generate the needed

propulsive lift and some forward momentum. As forward speed increases, the hull (aeroshell) generates some aerodynamic lift that compensate for inflight static heaviness and the propellers can be rotated to deliver only propulsive thrust during cruise flight. The maximum dynamic lift is 500 kg (1,102 pounds).



Bow view showing the flank thrusters vectored up for takeoff or landing. Source: Hansueli Krapf via Wikipedia



Flank thruster in the cruise position.



*Flank thruster in the "full up" position.
It can be vectored between 90° up and 30° down.*

Source, both photos: ZLT Zeppelin Luftschifftechnik GmbH



Zeppelin NT Eureka stern thrusters: one fixed lateral thruster and the main propulsion thruster that can be vectored 90° down.

Source: Wired, 7 June 2012



Source: Wikiwand.com

The rear propeller arrangement with a fixed lateral thruster and a vertically vectoring main thruster shown in cruise position (above) and vectored 90° down (below).



Source: Alchetron.com

In 2011 Goodyear started replacing its aging fleet of GZ-20A non-rigid airships (blimps) with three Zeppelin NT model LZ N007-101 semi-rigid airships. However, the name “Goodyear blimp” is still being used. The last of the original Goodyear blimps was retired on 14 March 2017.



*Goodyear’s new “blimp” – a semi-rigid Zeppelin LZ N007-101.
Source: Goodyear*



*Goodyear’s LZ N007-101 and the B-1 bomber at the start of
the Rose Parade, 1 January 2019. Author’s photo.*

You’ll find an illustrated history of the Goodyear blimp and the transition to the Zeppelin NT at the following link:

<http://www.goodyearblimp.com/relive-history/#page/2>

3. Flying in the Zeppelin NT

The closest you can come to an airship cruise today is a short commercial flight aboard a 12 – 14 passenger Zeppelin NT 07 airship, which is very similar in design to the new Goodyear airships. My wife and I took a flight on the Zeppelin NT in early June 2017, on a clear blue sky day, one day after a modest wind and rain storm had passed through the Friedrichshafen area and temporarily grounded zeppelin flight operations. Clearly, weather is much more of an issue for flying zeppelins than it is for winged heavier-than-air craft. Nonetheless, in suitable weather conditions, flight in a zeppelin is a remarkable experience. Our short tourist flight in the Zeppelin NT was hardly an adequate basis for a zeppelin commercial business model. However, based on this flight, it's much easier for me to visualize the utility of a large commercial airship for delivering cargo, passengers and emergency services to remote areas that are harder to reach with other modes of transportation.

You can book your flight on a Zeppelin NT at the following link:
<http://zeppelin-nt.de/en/homepage.html>



*One of the Zeppelin NT airships at the airfield in Friedrichshafen.
Source: ZLT Zeppelin Luftschifftechnik GmbH*



On approach to landing, with flank thrusters in the vertical position for lift. Source: Author's photo



Preparing to touch down and exchange passengers. Source: Author's photo



*Ready to exchange passengers.
Source: Author's photo*



*View of the German countryside from Zeppelin-NT.
Source: Author's photo*



View of Lindau on Lake Constance (the Bodensee) from Zeppelin-NT. Source: Author's photo



View of German countryside from Zeppelin-NT. Source: ZLT Zeppelin Luftschifftechnik GmbH

4. Selected Luftschiffbau Zeppelin GmbH patents related to Zeppelin NT

Patent US 5110070A - Rigid airship having ribs and long beams forming a carrier frame

Application granted: 5 May 1992

Inventors: Klaus Hagenlocher & Florian Windischbauer

Assignee: Luftschiffbau Zeppelin GmbH

Available from Google patents here:

<https://patents.google.com/patent/US5110070A/en>

Abstract:

“A rigid airship has a carrier frame with triangular cross-ribs interconnected by longitudinal beams, one connected to each corner of the triangle. Thus, prism-type frame sections are formed which are stiffened by diagonal tensioning members (D). The prism of each frame section (A) has two lateral sides and a base side. Each of the three sides is stiffened with two diagonal tensioning members. Junctions between neighboring frame sections are formed at the triangle corners. Carrier gas cells, the skin of which forms at least part of the airship skin, are secured in the frame sections. The base of each triangle cross-rib forms the base of the frame. One or more air chambers are formed in the belly of the airship below the base of the frame.”

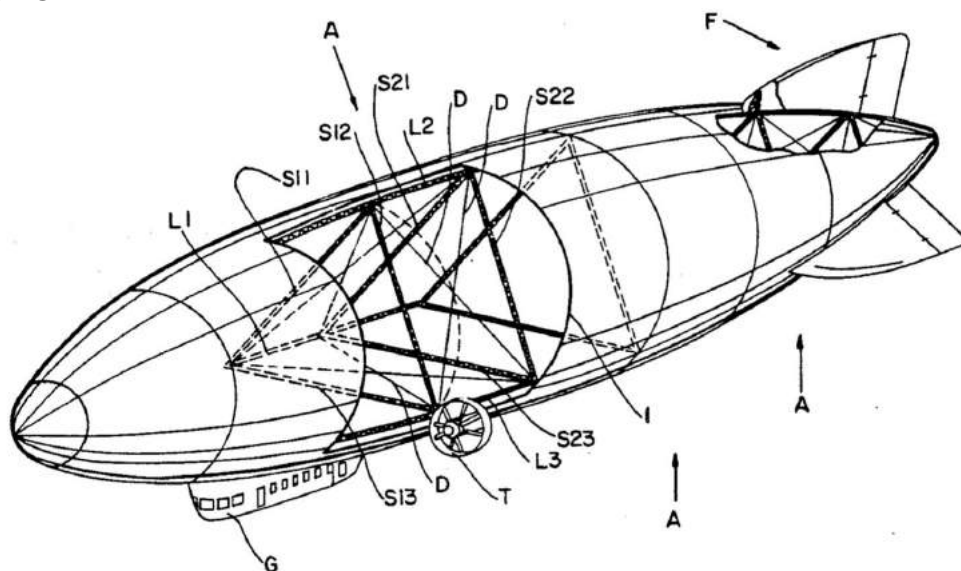

Patent US 5285986A - Rigid airship with a carrier frame of ribs and beams enclosed by skin sections forming an envelope

Application granted: 15 February 1994

Inventor: Klaus Hagenlocher

Assignee: Luftschiffbau Zeppelin GmbH

Available from Google patents here:

<https://patents.google.com/patent/US5285986A/en>

Abstract:

“An airship has a carrier frame with triangular cross-ribs arranged so that an apex faces upwardly and a base faces downwardly, whereby longitudinal beams at the corners of the triangles interconnect the cross-ribs. The carrier frame is enclosed by an envelope including at least three skin segments joined to each other along seams coinciding with the longitudinal frame beams. Each skin segment extends entirely from the bow to the stern and may include several strips. At least two steering air chambers are provided, one near the bow, the other near the stern for trimming purposes. The seams or at least one of the seams, is so constructed that it is readily openable and closable for providing access to the interior of the airship.”

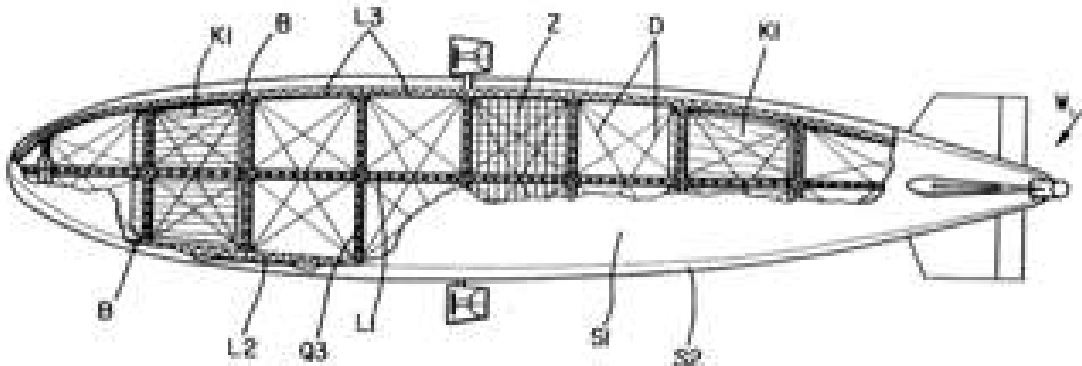

FIG. 6

5. For more information

- “New Zeppelin NT to be built in Friedrichshafen,” Lighter Than Air Society, 4 July 2018:
<https://www.blimpinfo.com/airships/new-zeppelin-nt-to-be-built-in-friedrichshafen/>
- “Zeppelin NT,” Alchetron.com, 1 July 2018:
<https://alchetron.com/Zepplin-NT>
- Scott Danneker, “Distributed Thrust and Autonomous Ground Handling,” Zeppelin Luftschifftechnik GmbH, AIAA, Aerospace Research Central, 22 August 2012:
<https://arc.aiaa.org/doi/10.2514/6.1999-3905>
- “Zeppelin NT,” Airships.net: <https://www.airships.net/zeppelin-nt/>
- “Zeppelin NT – Technical Data on the Zeppelin NT 07,” 2012:
<http://www.blimpinfo.com/wp-content/uploads/2012/01/Technical-data-of-the-Zeppelin-NT-07.pdf>
- “Zeppelin Production List,” Airport-Data.com :
<https://www.airport-data.com/manuf/Zepplin.html>

Other *Modern Airships* articles

- *Modern Airships - Part 1*: <https://lynceans.org/all-posts/modern-airships-part-1/>
 - Goodyear – civilian blimps
 - Zeppelin ZET
- *Modern Airships - Part 2*: <https://lynceans.org/all-posts/modern-airships-part-2/>
- *Modern Airships - Part 3*: <https://lynceans.org/all-posts/modern-airships-part-3/>